

National Cheng Kung University
Materials Corrosion Prevention Center
Daxue Road 1, Tainan
Tel. : (06)2757575-62942

ACKU research and Development
Foundation
Daxue Road 1, Tainan
Tel. : (06)2757575-56462

Material Erosion, Writing nr. MCPC 88037

Taiwan, 15/01/2000

TEST REPORT SUMMARISED TRANSLATION
--

Entrusted to : Sincere Bidder Ltd Contact person : Peter Lin
Address : 9F-2, Roosevelt Road 253, Section 3, Taibei, Taiwan

Tel. : (02)2362-8189
Fax : (02)2362-2374

Name of the test : 1000 hours salt spray test

Date of receipt : 26/10/99

I. Testing method

Based on the ASTM B 117-94 norm, the corrosion of the surface will be observed.

II. Circumstances of the test

(1) Circumstances in the spraying room

Item	During preparation	During the test
Density of the salt liquid (g/Lt)	50 g/Lt	40 to 60 g/Lt
pH value	6.5 pH	6.5 to 7.5 pH
Condensed air pressure (Kgf/cm ²)	-	0.7 to 1.7 Kgf/cm ²
Temperature saturation pail (°C)	-	45 to 49 °C
Temperature testing barrel (°C)	-	33 to 37 °C
Quantity of spray (ml/hour)	-	0.5 to 3.0 ml/hour

(2) Duration of the test

The total duration of the test is 1000 hours, divided in unequal periods in order to examine and to evaluate the results of the samples.

III. The sample surface that has to be examined and evaluated

(1) Size of the test plates :

a square of 100 mm x 100 mm x 5 mm. (See picture 1.)

- (2) Material substance of the test plates (basic material) :
 carbon steel : 3 plates
 galvanised by hot-dip : 6 plates
- (3) Treatment of the test plates : we respectively apply the organic zinc powder coating in layers of 60µm, 90µm and 120 µm onto the carbon steel plates and the hot-dip galvanised steel plates. On the 3 remaining hot-dip galvanised plates we do not apply any topcoat. All the test plates are not sealed on the sides and we do not make any cuts. The evaluation of the surface and the serial number of the test plate after the salt spray test has been executed , can be found in table 1.

Picture 1 The measurements of the test plates
 A : The sample surface that has to be examined and evaluated

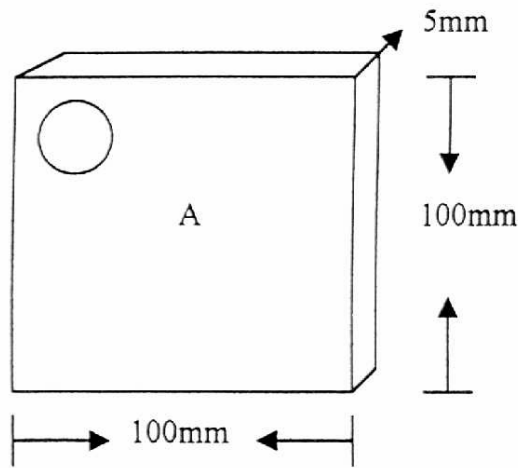

Table 1

Serial number	1	2	3	4	5	6	7	8	9
basic material	hot-dip	hot-dip	hot-dip	hot-dip	hot-dip	hot-dip	carbon steel	carbon steel	carbon steel
topcoat (layer thickness)	no topcoat	no topcoat	no topcoat	organic zinc powder (60 µm)	organic zinc powder (90 µm)	organic zinc powder (120 µm)	organic zinc powder (60 µm)	organic zinc powder (90 µm)	organic zinc powder (120 µm)

IV. Test results

- (1) The salt spray test had a total duration of 1000 hours.
- (2) When the salt spray test had reached 100, 172, 275, 365, 659, 666, 778, 857, 967 and 1000 hours, the surface appearance of each sample was examined and the results were noted in table 2.
- (3) Picture 2 is a picture of the surface appearance of the sample with serial number 2 (a hot-dip galvanised plate without topcoat) after the 1000 hours

salt spray test. On the surface of the sample you can clearly distinguish the formation of red rust.

- (4) Picture 3 is a picture of the surface appearance of the sample with serial number 4 (a hot-dip galvanised plate with 60 µm topcoat) after the 1000 hours salt spray test. There is no red rust on the surface of the sample, but there is white rust and appearance of bubbles.
- (5) Picture 4 is a picture of the surface appearance of the sample with serial number 8 (a carbon steel plate with 90 µm topcoat) after the 1000 hours salt spray test. On the surface of the sample there is no red rust and no formation of bubbles, but there is formation of white rust.

Picture 2 The surface appearance of the sample with serial number 2 after the 1000 hours salt spray test.

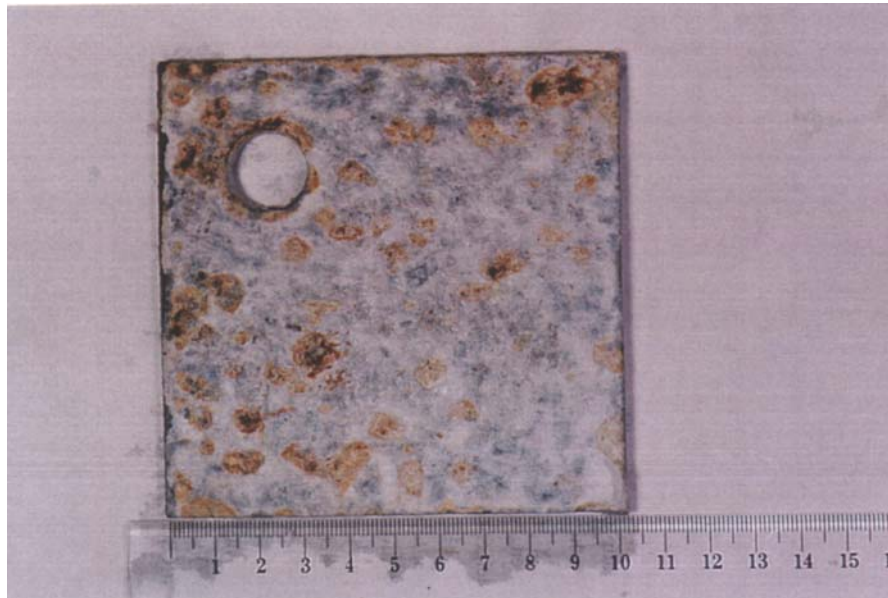

Picture 3 The surface appearance of the sample with serial number 4 after the 1000 hours salt spray test.



Picture 4 The surface appearance of the sample with serial number 8 after the 1000 hours salt spray test.

